

## HOOK ACE

Crane Scale (500kg~5t)



### Features;

- Compact design & High accuracy
- Cast aluminium housing
- 25mm height LCD/LED display
- Sturdy swivel hook("Crosby" or equivalent)
- 24bit Sigma-delta A/D converter
- Easy access rechargeable battery
- Watertight push button switch
- I.R. remote control (on/off, zero, net/gross, tare, hold)
- Optional wireless display & controller

### SPECIFICATIONS

| Model                  | LCBD   | LCBE       |
|------------------------|--|------------|
| Rated capacity         | 500kg, 1, 2, 3, 5t   |            |
| Display                | LCD (25mm)   | LED (25mm) |
| Accuracy               | 1/2000, 1/2500, 1/3000   |            |
| Power                  | 6 volt lead-acid rechargeable battery  |            |
| Battery operating time | 150 hours  | 80 hours   |
| Recharging time        | Approx. 4 hours  |            |
| Operating temp.        | -10°C ~ 50°C   |            |
| Enclosure              | Cast aluminium, IP54   |            |
| Safe overload          | 200% of rated capacity   |            |
| Ultimate overload      | 500% of rated capacity   |            |
| Hook                   | Swivel hook with thrust bearing  |            |
| Switches               | On/Off, Zero, Net/Gross, Tare  |            |
| Annunciators(LED lamp) | Continuation(Auto power OFF), Zero, Net, Gross   |            |
| Accessories            | (1) Battery, 6 volt rchargeable<br>(2) Battery charger (Free voltage, AC85~260V)<br>(3) I.R. Type Remocon                      |            |
| Option                 | 1) Wireless Handy Indicator(Model : BS-52R)<br>2.4GHz Bluetooth Communication<br>2) Wireless Desktop Indicator / Large Display |            |

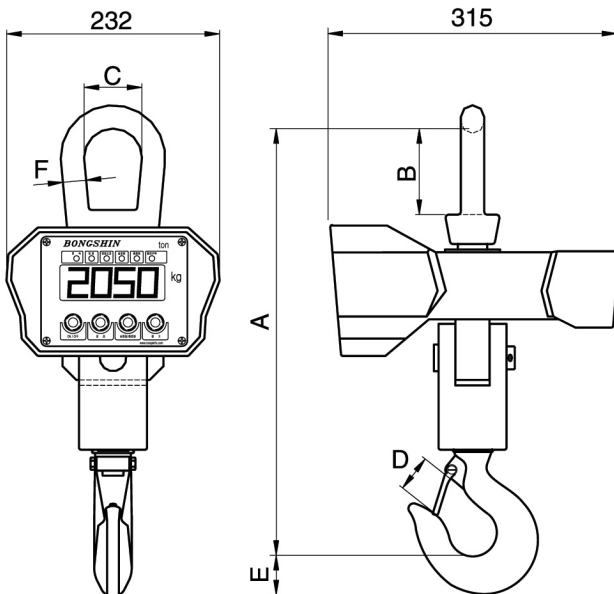

### ORDERING INFORMATION

**LCBE - 5T**  
 MODEL: LCBE, LCBD  
 CAPACITY: 500kg, 1, 2, 3, 5 t



BS-52R (Option)

### Dimmension-mm

| MODEL              | Capacity | Resolution | A   | B  | C  | D  | E  | F    | Weight |
|--------------------|----------|------------|-----|----|----|----|----|------|--------|
| LCBD(LCBE) - 500kg | 500kg    | 0.2kg      | 335 | 67 | 50 | 31 | 29 | 19   | 12kg   |
| LCBD(LCBE) - 1 t   | 1t       | 0.5kg      |     |    |    |    |    |      |        |
| LCBD(LCBE) - 2 t   | 2t       | 1kg        |     |    |    |    |    |      |        |
| LCBD(LCBE) - 3 t   | 3t       | 1kg        | 470 | 89 | 63 | 43 | 46 | 25.4 | 18kg   |
| LCBD(LCBE) - 5 t   | 5t       | 2kg        |     |    |    |    |    |      |        |