

Model CDBM Series

Compression Load Cell
Specially Designed
For Truck Scales (5t~ 10t)



Specially designed for midium size truck scales in harsh environments. The effective integration of the CDBM is that mount and double ended shear beam load cell eliminates the need for troublesome check roads, links, expansion assemblies and other peripheral hardware. The unique spherical ball point loading mechanism makes lateral movement of the assembly possible, while controlled floating of the scale deck is allowed.

- High overload tolerance
- Self centering design
- Alloy tool steel construction for high accuracy.
- Electroless nickel plated for corrosion resistance.
- 0.03% accuracy
- Center loaded double ended shear beam design
- Protection against harsh environment

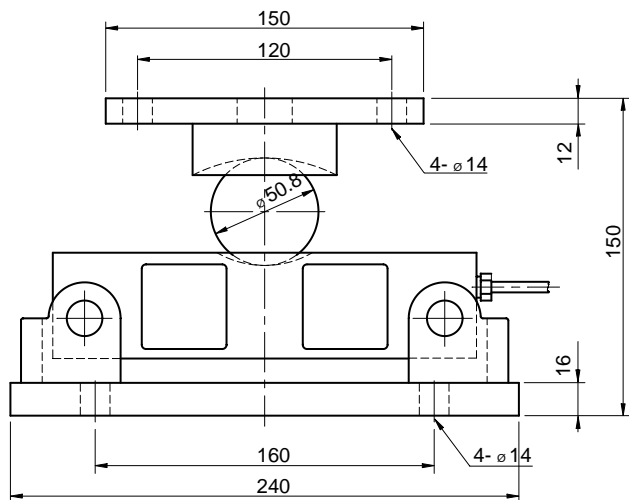
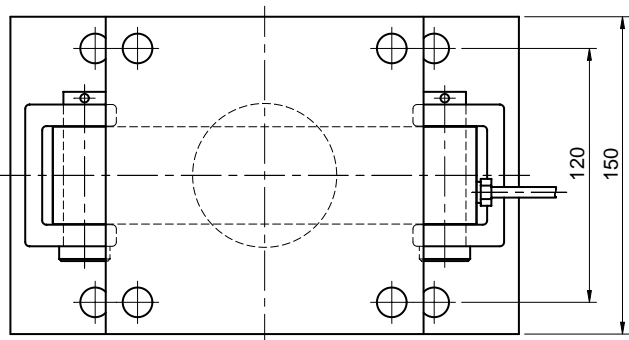

SPECIFICATIONS

MODEL	CDBM
Rated capacity (R.C.)	5, 10t
Rated output(R.O.)	2mV/V \pm 0.25%
Non-linearity	\leq 0.03% R.O.
Hysteresis	\leq 0.03% R.O.
Non-repeatability	\leq 0.03% R.O.
Creep error	\leq 0.03% in 20min.
Zero balance	\leq 1% R.O.
Compensated temperature range	-10 ~ 70°C
Operating temperature range	-20 ~ 80°C
Temp. effect on rated output	\leq 0.02% LOAD/10°C
Temp. effect on zero balance	\leq 0.03% R.O./10°C
Terminal input resistance	790 Ohms \pm 30 Ohms
Terminal output resistance	700 Ohms \pm 5 Ohms
Insulation resistance (Min.)	2000 MOhms at 50V DC
Excitation Voltage	10V(Recommended) /15V(Maximun)
Electrial connection	ϕ 5mmx 3m(22AWG x 4Core Shielded)
Protection class	meets IP 67
Safe overload	150% R.C
Ultimate overload	300% R.C

ORDERING INFORMATION

CDBM - 10T

MODEL CAPACITY
5, 10t

WIRING INFORMATION

RED : EXC. (+) WHITE : EXC. (-)
GREEN : SIG. (+) BLUE : SIG. (-)
BARE : GND