

Skylift - II series Crane Scales (10t ~ 30t)

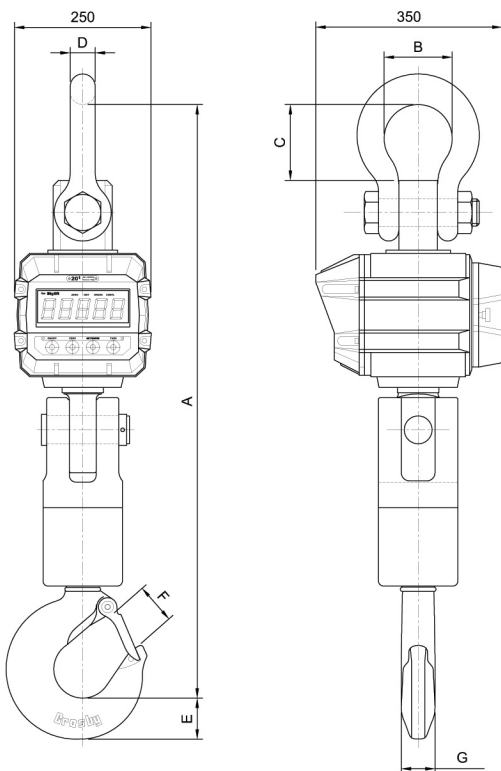

I.R. Remocon



- Features;**
- Robust design & High accuracy
 - Durable cast aluminium housing
 - Large brightness LED display(38mm)
 - Sturdy swivel hook("Crosby" or equivalent)
 - 24bit Sigma-delta A/D converter
 - Easy access rechargeable battery
 - Watertight push button switch
 - I.R. remote control (on/off, zero, net/gross, tare, hold)
 - Optional wireless display & controller

SPECIFICATIONS

Model	NCS
Rated capacity	10, 15, 20, 30t
Display	38mm height LED, 5 digit
Accuracy	1/2000, 1/1500
Power	6 volt lead-acid rechargeable battery
Battery operating time	80 hours between recharging
Recharging time	Approx. 4 hours
Operating temp.	-10 °C~ 50 °C
Enclosure	Cast aluminium, IP64
Safe overload	200% of rated capacity
Ultimate overload	500% of rated capacity
Hook	Swivel hook with thrust bearing
Switches	On/Off, Zero, Net/Gross, Tare
Annunciators(LED lamp)	Continuation(Auto power OFF), Zero, Net, Gross
Accessories	(1) Battery, 6 volt rchargeable (2) Battery charger (Free voltage, AC85~260V) (3) I.R. Type Remocon
Option	1) Wireless Handy Indicator(Model : BS-52R) 2.4GHz Bluetooth Communication 2) Wireless Desktop Indicator / Large Display
Remarks	Upper link 1) 10t : Eye nut ("Crosby" G-400 or Eq.) 2) 15, 20, 30t : Shackle ("Crosby" G-2130 or Eq.)

15,20,30t



BS-52R
(Option)

ORDERING INFORMATION

NCS - 10T

MODEL

CAPACITY

10, 15, 20, 30 ton

Dimension (mm)

Model	R.C.	Resolution	A	B	C	D	E	F	G	Weight(kg)
NCS - 10T	10t	5 kg	735	104	150	38 x 38	66	61	56	55 kg
NCS - 15T	15t	10 kg	840	98	110	38 x 41	77	81	61	62 kg
NCS - 20T	20t	10 kg	1110	127	143	47 x 57	77	81	61	90 kg
NCS - 30T	30t	20 kg	1302	146	145	51 x 61	116	108	92	190 kg